



PW-10P-MD

DIMENSIONAL SCHEMATIC AND PERFORMANCE

DIMENSIONS mm

not to scale
specifications are subject to change

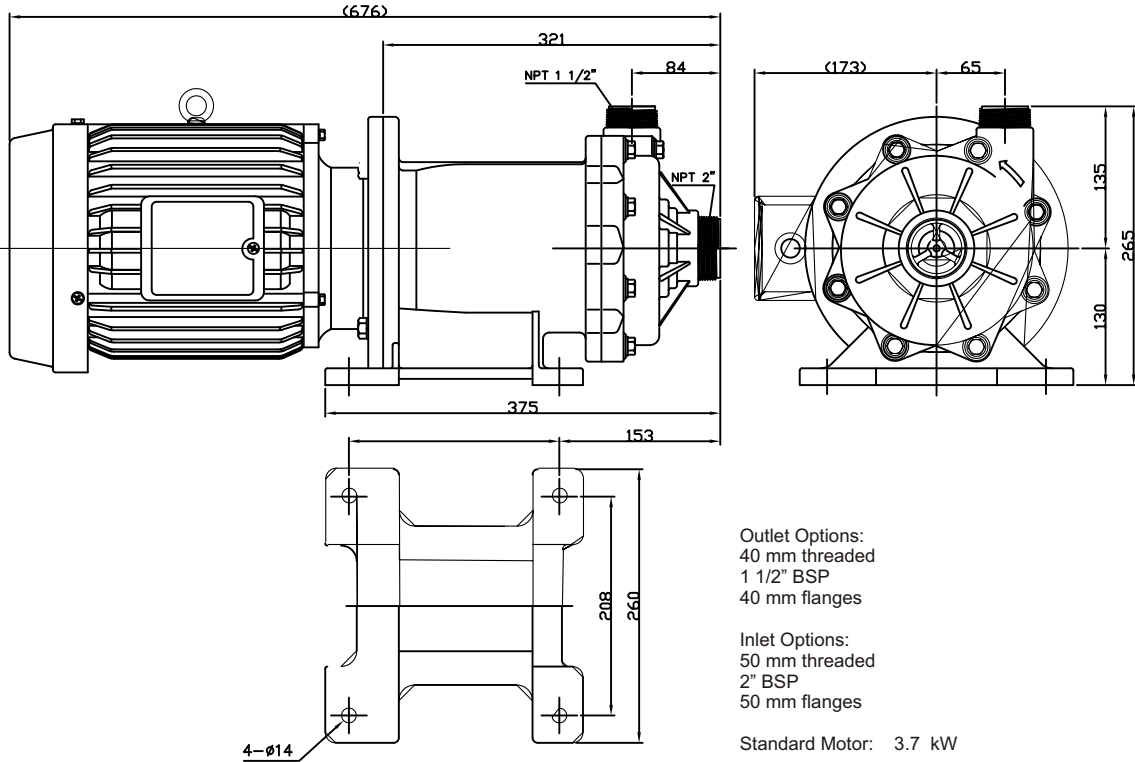

Details may change depending upon the motor specified

PERFORMANCE

Tests obtained
50 hz 2860 rpm
— 1.1 SG

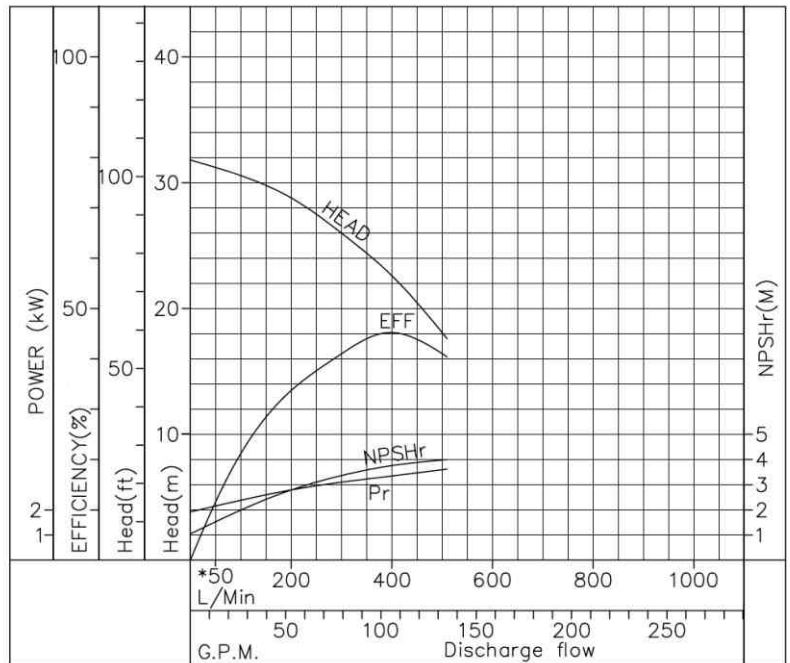

Performance may change depending upon the motor specified